

TYPE

SA

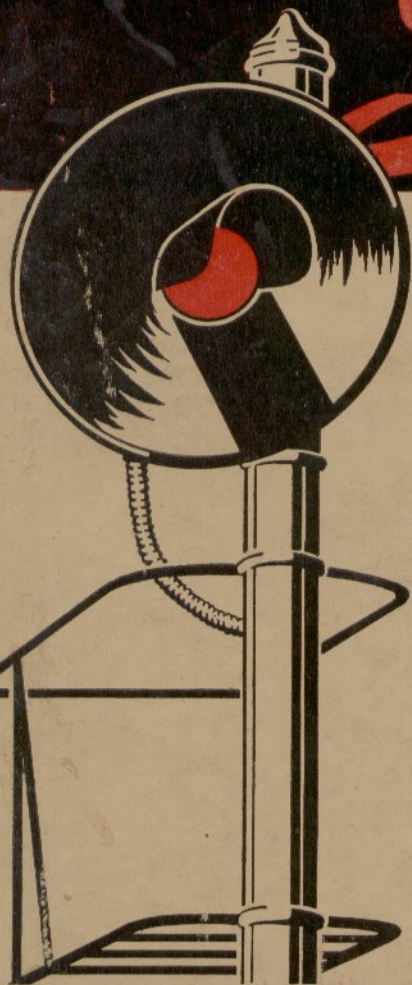

**COLOR-LIGHT
SIGNAL**

**INSTALLATION
OPERATION
MAINTENANCE**

HANDBOOK 29

GENERAL RAILWAY SIGNAL COMPANY

TYPE SA COLOR-LIGHT SIGNAL

SEARCHLIGHT TYPE

INSTALLATION
OPERATION
MAINTENANCE

HANDBOOK 29
October 1947

GENERAL RAILWAY SIGNAL COMPANY
ROCHESTER 2, NEW YORK

TYPE SA COLOR-LIGHT SIGNAL

Copyright 1947
General Railway
Signal Company
Rochester 2, N. Y.



TABLE OF CONTENTS

	Page
Introduction	5
Locating the Signal	5
Mounting the Side-of-Mast Signal	5
Mounting the Top-of-Mast Signal	7
Running the Wires to Signal Housing	7
Inserting or Replacing the Lamp.	9
Cleaning Reflector and Lenses.	9
Inserting the Signal Operating Mechanism	11
Connecting the Control Wires.	13
Checking Lamp Voltage.	19
Checking Operating Values	19
Sighting the Signal	21
Adjusting the Close-up Beam.	25
Replacing a Broken Lens or Roundel.	27
The Optical System	27
Why the Red Color Disc Is Slanted	29
Changing Signal from Straight Track to Curved Track Application	30
Check These Before Placing Signal in Service	31
Don'ts	31
Ordering References	33

TYPE SA COLOR-LIGHT SIGNAL

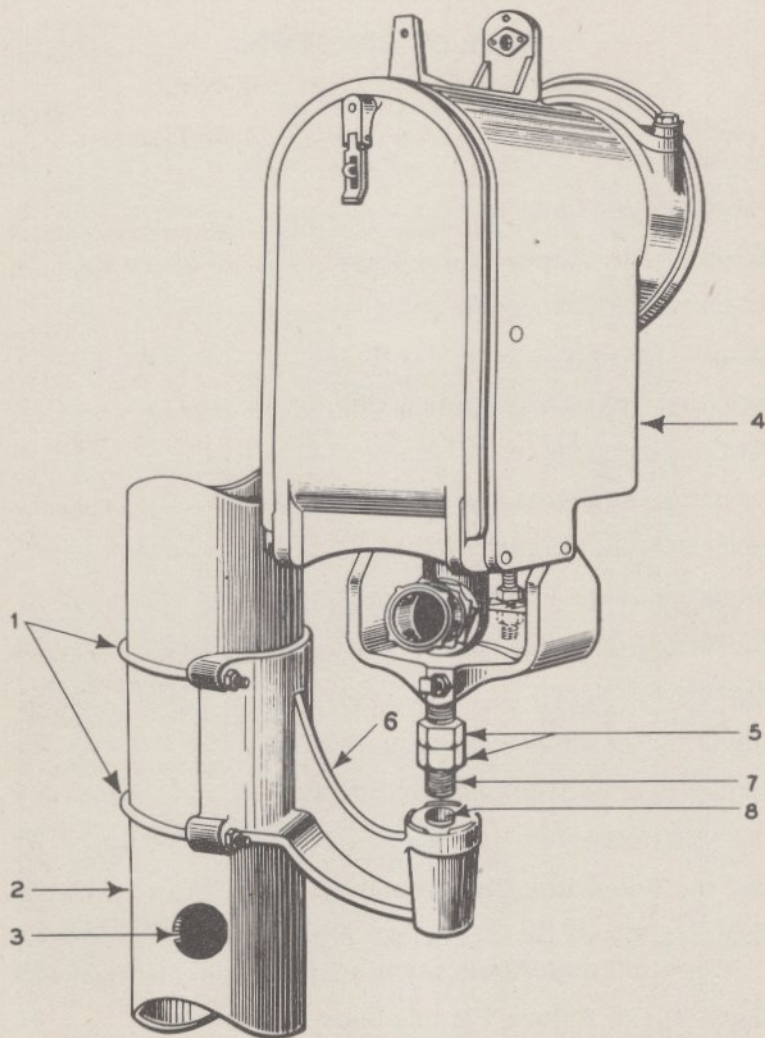

Figure 1. Mounting the Type SA signal housing on the side of the mast.

TYPE SA COLOR-LIGHT SIGNAL

INSTALLATION - OPERATION - MAINTENANCE

Introduction

The object of this handbook is to give information about the installation, operation, and maintenance of the Type SA color-light signal.

Locating the Signal

For best results, the high signal should be so located with respect to the track that the lens is as nearly as possible on a level with the eyes of the engineman and as close to the track as clearances will permit. It will be found that this condition normally calls for mounting the signal on the left-hand side of the mast as viewed by the approaching engineman.

Mounting the Side-of-Mast Signal, Figure 1

Housing 4, Figure 1, may be mounted with bracket 6 already attached; or bracket 6 may be attached to mast 2 first, and housing 4 may then be attached to bracket 6.

When using the latter method, first attach bracket 6 to mast 2 by means of U-bolts 1. Then remove nuts 5 from stud 7, and drop the stud through vertical pivot hole 8 in bracket 6. Next replace nuts 5 on stud 7, leaving the nuts somewhat loose until the signal has been properly aligned with the track as will be described further on.

Where flexible conduit is used for the wires from the mast to the signal, care must be used in locating bracket 6 on the mast to insure its proper position in relation to conduit hole 3.

TYPE SA COLOR-LIGHT SIGNAL

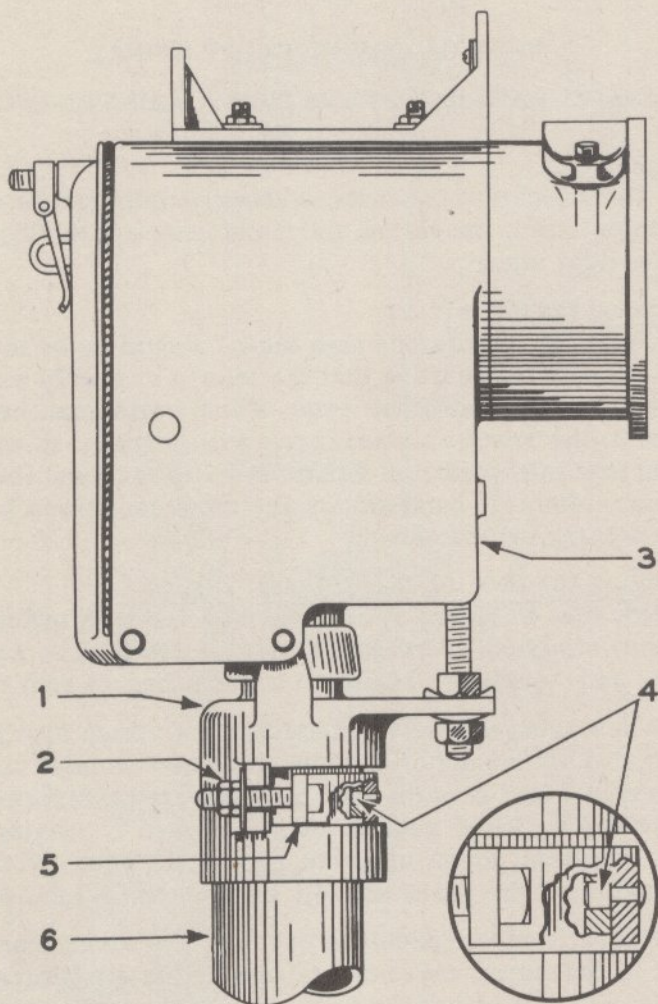

Figure 2. Mounting the Type SA signal housing on the top of the mast.

Mounting the Top-of-Mast Signal, Figure 2

Loosen nuts 2, Figure 2, so that socket 1 will fit on mast 6. Then place housing 3, with socket 1 attached, on top of the mast so that the stud which is a part of clamp 5 will fit into hole 4. Leave nuts 2 somewhat loose until the signal has been properly aligned with the track as will be described further on.

When mounting the mast, it is important that hole 4 be located in approximately the same direction as the signal beam.

Running the Wires to Signal Housing

After the signal housing has been mounted, the next step is to run the operating wires. For a d-c. signal, there will be one pair of wires for the line coil of the signal operating mechanism, one pair for the lamp circuit, and such other wires as may be required by the contacts. A-c. signals require an additional pair of wires for the local coil.

It is more convenient to run the wires before the signal mechanism is inserted into the housing. Fan the wires out and lay them flat upon the bottom of the housing with the ends lying in a row along the bottom edge and hanging out of the door as shown in Figure 5.

TYPE SA COLOR-LIGHT SIGNAL

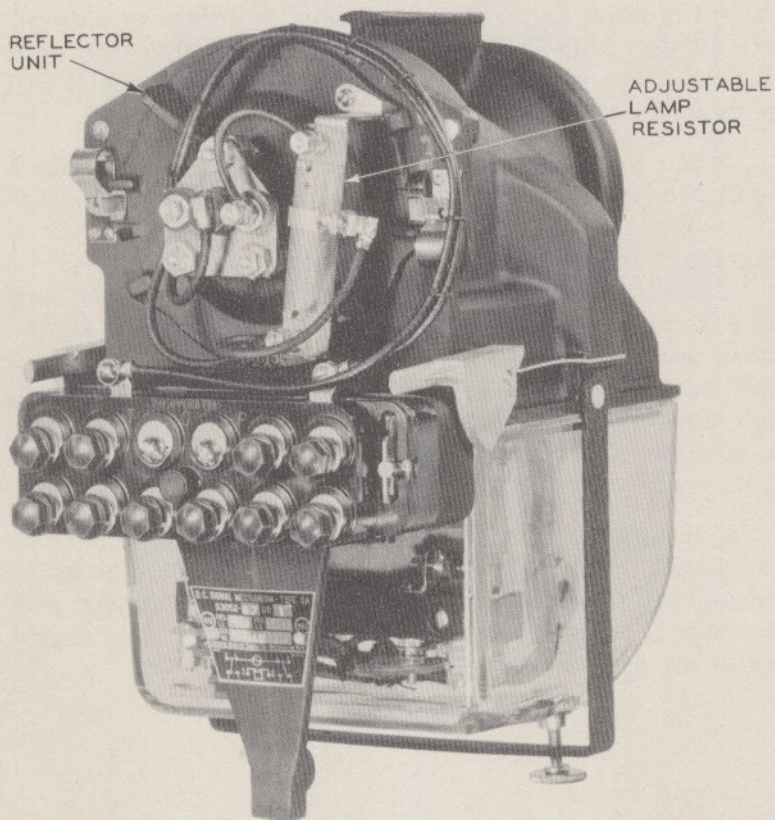

Figure 3. Type SA signal operating mechanism.

Inserting or Replacing the Lamp, Figure 3

To insert the lamp in the signal mechanism, turn reflector unit, Figure 3, clockwise until it unlatches and then withdraw it. If it is raining or snowing, protect reflector surface if hot, as sudden cooling may crack it. Be sure that the lamp is properly seated in its socket before replacing the reflector unit; then turn the reflector unit counterclockwise to lock it in place.

Cleaning Reflector and Lenses

The reflector, lenses and cover glasses should be clean when installed and should be cleaned periodically thereafter with a chamois skin or a soft, lint-free cloth. To avoid scratching lenses, gritty substances must not be allowed to accumulate in the chamois skin or cloth. Alcohol or lacquer thinner will help in removing incrustations from the outer lens.

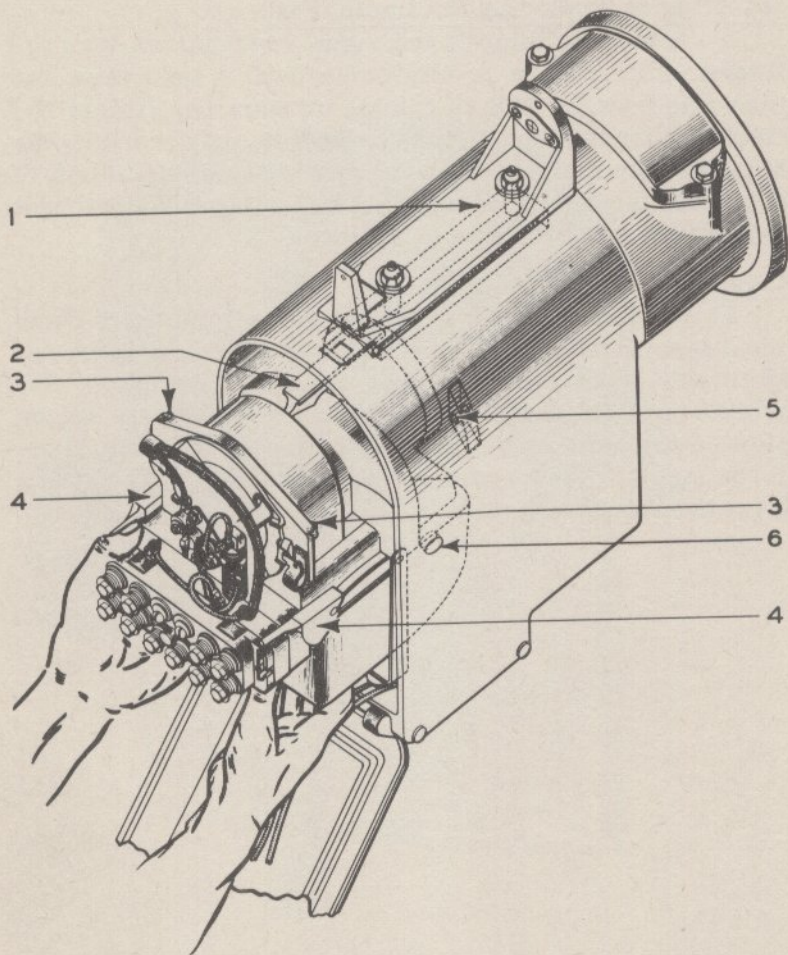

Figure 4. Inserting the signal operating mechanism into the housing.

Inserting the Signal Operating Mechanism, Figures 3, 4, and 5

The signal mechanism, Figure 3, is securely packed in a special carton and shipped separately from the signal housing. Signal mechanisms should be transported to the site of the installation in their cartons and the same care used in unpacking and handling as would be used in the handling of signal relays in general.

After the wires have been run into the housing and arranged as shown in Figure 5, the next step is to insert the mechanism into the housing. Pick the mechanism up as shown in Figure 4, grasping the plug coupler or terminal block with one hand and supporting the mechanism with the other hand underneath the glass case.

Insert hanger 2 into track 1 and thrust the mechanism forward until pins 3 enter holes 5 (lug in opposite side of housing is not visible in Figure 4). Locking cams 4 will then automatically snap down behind locking pins 6 (only one visible in Figure 4) and lock the mechanism in place.

It is recommended that both locking cams 4 be pressed down with the fingers at the same time to insure that the mechanism is properly positioned in the housing. Avoid excessive pressure when doing this. If the cam handles do not lie within a few degrees of horizontal, the mechanism is not in its place. Figure 5 shows the mechanism properly locked inside the housing.

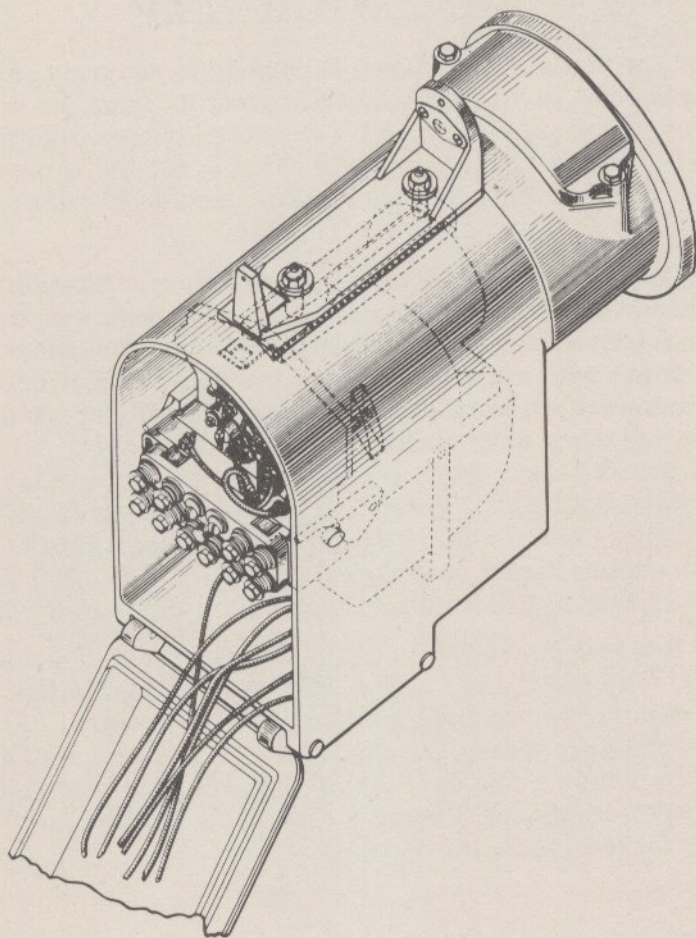

Figure 5. Signal operating mechanism properly positioned and locked in the signal housing.

Connecting the Control Wires, Figures 6-10

After the signal mechanism has been securely locked in place, the wires may be cut to length and connected to their respective binding posts.

D-c. signal operating mechanisms may have either 2 dependent front and back contacts or 8 independent contacts (4 front and 4 back). Mechanisms provided with 2 dependent contacts are equipped with either a plug coupler or a 2-row terminal block. Figure 6 shows the internal and external wiring for a mechanism equipped with 2 dependent contacts and a plug coupler. When a 2-row terminal block is supplied in place of a plug coupler, wiring is same except that lamp and resistor are connected as shown in Figure 8.

D-c. signal operating mechanisms with 8 independent contacts are equipped with either a double plug coupler (see Figure 7 for wiring) or a 3-row terminal block (see Figure 8 for wiring).

A-c. signal operating mechanisms are provided with 2 dependent contacts and are equipped with either a plug coupler or with a terminal block. Wiring connections are the same in either instance. Figure 9 shows typical wiring for an a-c. mechanism with the lamp on an independent circuit. Contact connections are the same as shown in Figure 6. Figure 10 shows wiring for an a-c. mechanism with the lamp connected in series with the local coil. Contact connections are the same as shown in Figure 6.

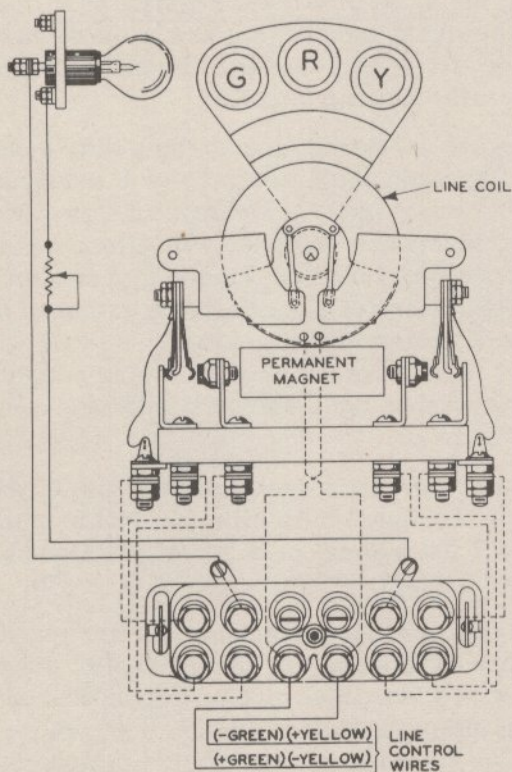

Figure 6. Simplified diagram of Type SA d-c. signal operating mechanism with two dependent front and back contacts. Dotted lines indicate internal wiring. Solid lines indicate external wiring. Plug coupler is shown. Wiring is same on models equipped with terminal blocks (except lamp and resistor, which are connected as shown in Figure 8).

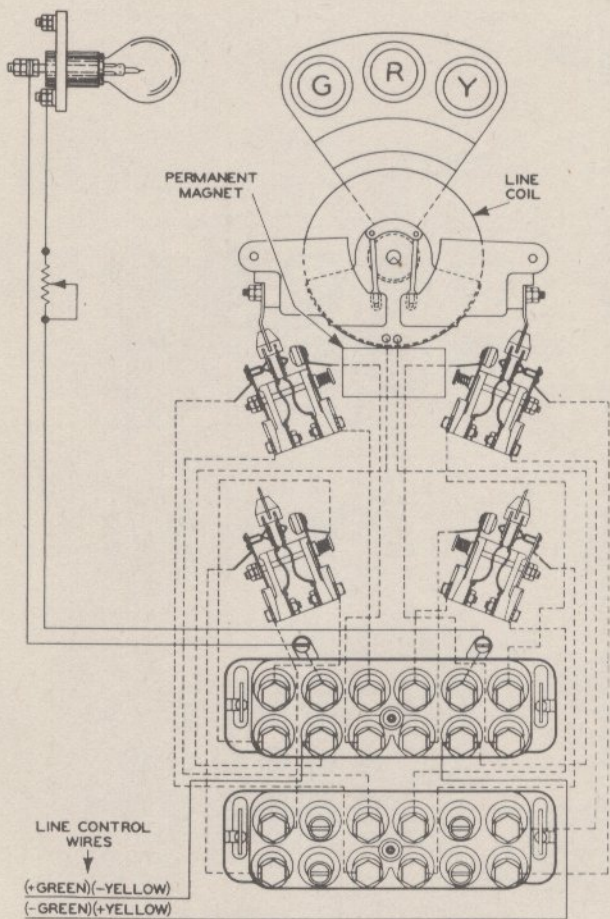

Figure 7. Simplified diagram of Type SA d-c. signal operating mechanism with 8 independent contacts and 2 plug couplers. Dotted lines indicate internal wiring. Solid lines indicate external wiring.

TYPE SA COLOR-LIGHT SIGNAL

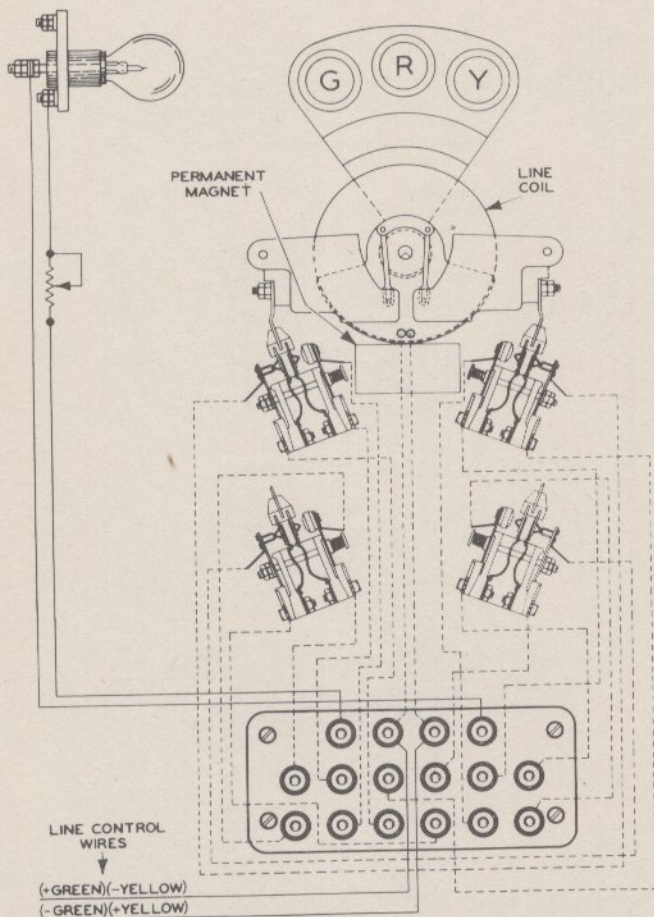

Figure 8. Simplified diagram of Type SA d-c. signal operating mechanism with 8 independent contacts and 3-row terminal block. Dotted lines indicate internal wiring. Solid lines indicate external wiring.

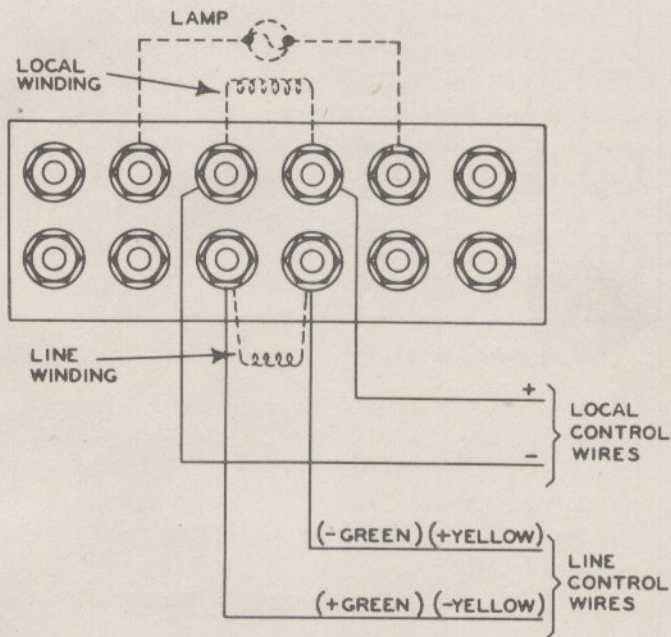

Figure 9. Typical connections for Type SA a-c. signal operating mechanism. Lamp is on independent circuit. Wiring is same when plug coupler is used instead of terminal block shown.

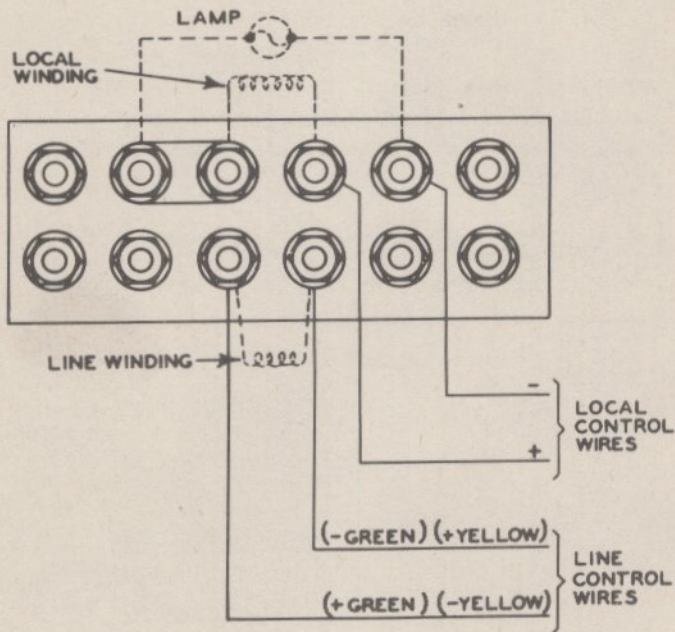

Figure 10. Typical connections for Type SA a-c. signal operating mechanism. Lamp is connected in series with local winding. Wiring is same when plug coupler is used instead of terminal block shown.

Checking Lamp Voltage, Figure 3

After making sure that the wires to the signal have been properly connected, the light energy should be applied. The candlepower of the lamp is greatly affected by voltage changes. The lamp voltage should be checked at the time of installation and at any time thereafter when alterations have been made in the power supply that cause a change in voltage at the signal. Excessive voltage greatly reduces the burning life of the lamp. Under-voltage materially reduces the candlepower and, consequently, the range of the signal.

Connect the voltmeter across the lamp terminals on the reflector unit and adjust the voltage by varying lamp resistor shown in Figure 3.

In general, it is recommended that lamps be burned at 10 percent under rated voltage to increase the average life. For low-wattage lamps, it will be found necessary to burn them at or close to the rated voltage in order to obtain adequate daylight range. It is also recommended that nothing lower than a 10-watt lamp should be used in a stepped-lens signal.

Checking Operating Values

The operating current of d-c. mechanisms (or the operating voltage of a-c. mechanisms) should be enough above the specified working values to insure a margin in case of voltage drop which may occur if batteries are drained during a power outage. Current should not exceed 50 percent of the rated value given on the sticker attached to the outside of the mechanism. Excessive current is wasteful and does not provide any better operation of the signal.

TYPE SA COLOR-LIGHT SIGNAL

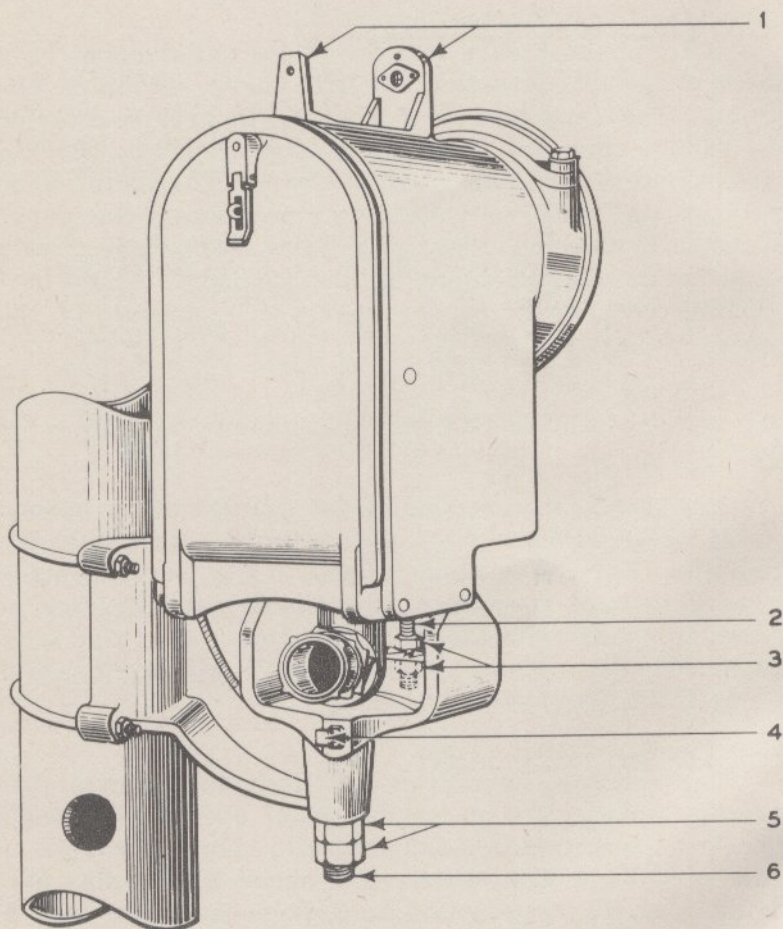

Figure 11. Sighting the Type SA side-of-mast signal.

Sighting the Signal, Figures 11 and 12

On all signals except dwarf signals, a sighting device is provided on top of the housing (see reference 1, Figure 11 or 12). This device has been adjusted in the factory and should not be removed or adjusted in the field. Before sighting the signal, however, it may be necessary to clean the peep-hole in the rear of the sighting device with a pin or a fine wire, as it sometimes gets clogged with paint and dirt. By sighting through the hair-line peep sight and by manipulating the separate horizontal and vertical adjustments, the light beam is aligned as desired.

To sight a side-of-mast signal housing, Figure 11, first loosen set screw 4 and nuts 5 on stud 6. This will allow you to swing the housing in a horizontal plane. By looking through sight 1, the signal housing may be swung and set so that the vertical cross hair in sight 1 centers on the point at which it is desired to project the axis or most intense part of the main beam. Lock the housing in this position by tightening set screw 4 and nuts 5.

The signal housing should then be tipped up or down by means of adjusting stud 2 and nuts 3 until the horizontal hair line in sight 1 centers on the desired point. Lock the housing in this position by tightening nuts 3.

TYPE SA COLOR-LIGHT SIGNAL

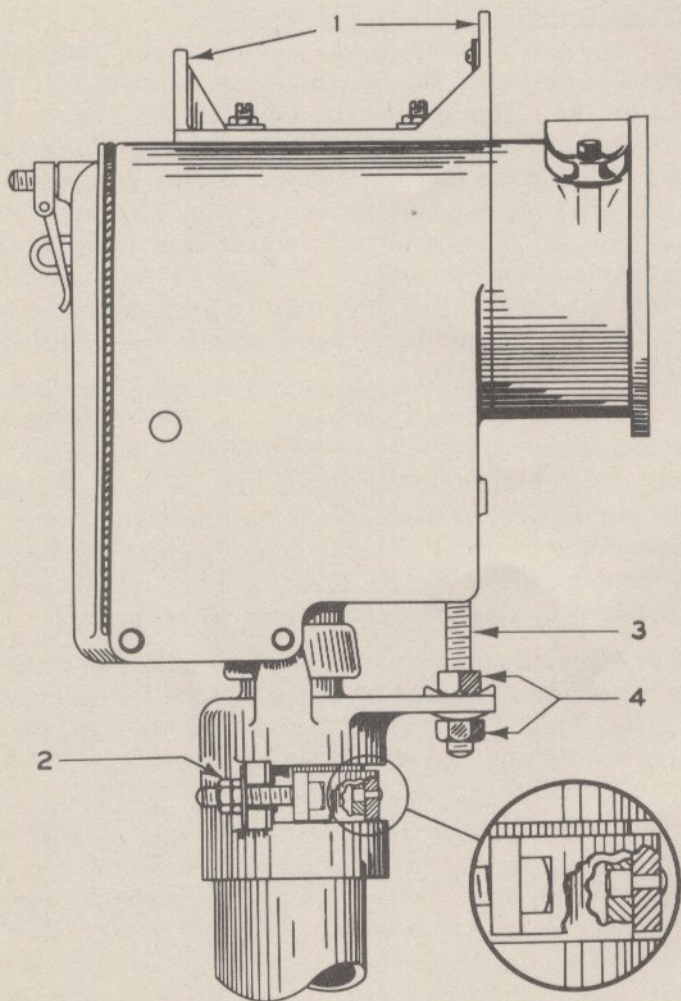

Figure 12. Sighting the Type SA top-of-mast signal.

To sight top-of-mast signal housing, Figure 12, loosen nuts 2 (nuts on other side not shown in Figure 12), and then tighten the adjusting nut on the side toward which it is desired to rotate the signal housing. When the vertical hair line in sight 1 centers on the point desired, clamp the housing in place by drawing up nut 2 on the opposite side. Then lock both nuts 2 by tightening up their jam nuts.

Vertical adjustment is accomplished by adjusting nuts 4 on stud 3. Follow the same procedure as for the side-of-mast signal.

Bridge signals which are mounted on girders and dwarf signals are provided with bases that have slotted holes for the mounting bolts. The slotted holes allow the signal to be adjusted horizontally. Vertical adjustment is accomplished the same as for side-of-mast and top-of-mast signals.

Dwarf signals are not provided with sighting devices. They are sighted by observing their aspects from along the track. When the two-arm dwarf signal is aligned with the track, it is only necessary to align the lower arm, since the upper arm has been aligned with the lower arm at the factory.

After the signal has been sighted by use of the sighting device, check the alignment by observing the aspect from the track. By viewing the signal from both sides of the point along the track to which the beam has been directed and from positions in advance of and behind this point, it can readily be determined whether the beam is properly directed. It should seldom be necessary to make any compensating adjustments.

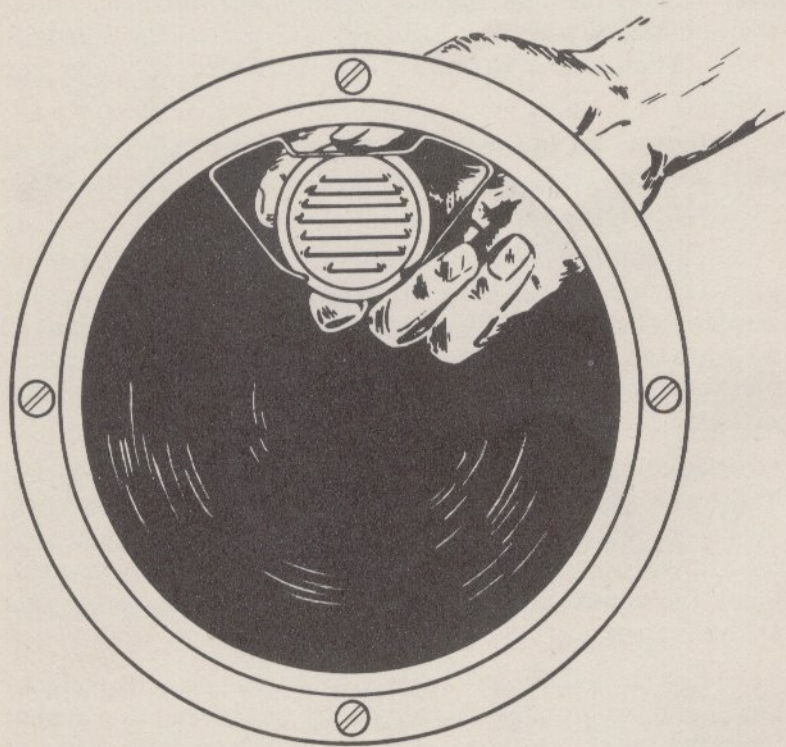

Figure 13. Adjusting the close-up deflecting roundel in a compound-lens signal.

All Type SA signal operating mechanisms and housings are carefully adjusted at the factory before shipment to insure that any compound-lens mechanism will function equally well in any compound-lens housing and that any stepped-lens mechanism will function equally well in any stepped-lens housing.

Make certain that you are using a compound-lens mechanism in a compound-lens housing, or a stepped-lens mechanism in a stepped-lens housing.

Attempts to adjust the lamp receptacle in the field will most likely result in a poorer rather than a better focus.

Adjusting the Close-up Beam, Figures 13, 14, and 15

As shown in Figure 14, the compound-lens signal is equipped with a small 40-degree deflecting roundel to provide a close-up aspect for the engineman who stops under a high signal. This roundel is installed at the top of the lens barrel. The roundel can be turned in its support to direct part of the beam downward and across the track.

To adjust the small deflecting roundel, remove the handhole cover on the lens barrel, reach in as shown in Figure 13, and turn the roundel in the direction desired. Then replace handhole cover.

In the stepped-lens signal, Figure 15, the center of the outer lens is modified to divert part of the beam for a close-up aspect. It can be adjusted by rotating the lens as required, after loosening the outer bezel ring by backing off the mounting screws. When the adjustment is completed, tighten up the mounting screws.

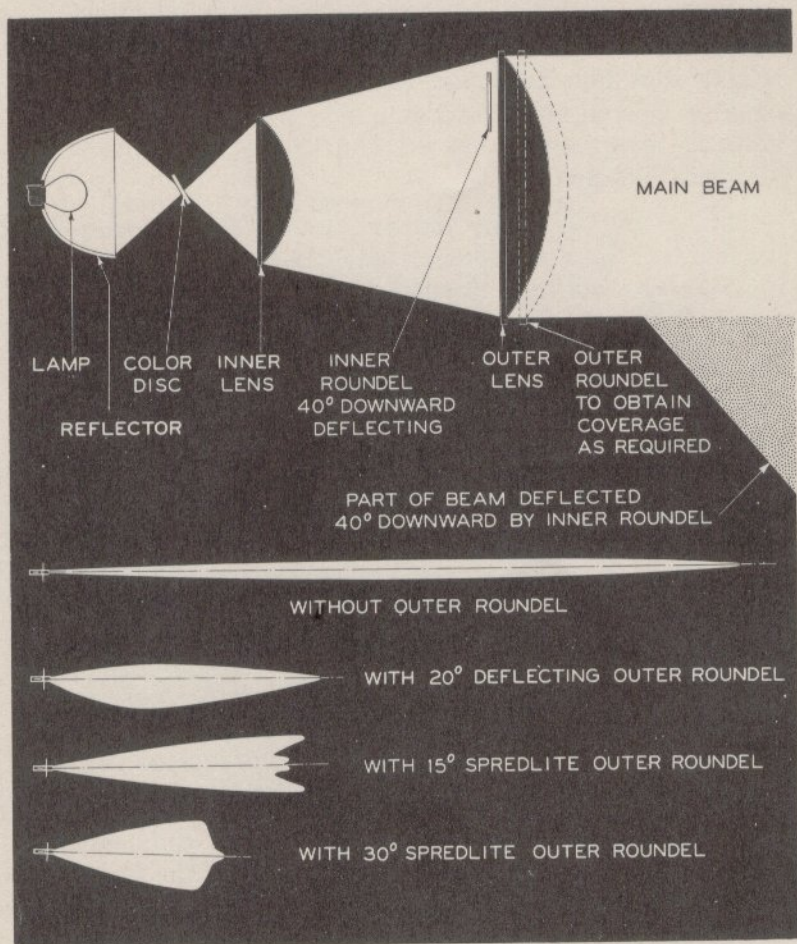

Figure 14. Compound-lens system showing beam coverages with different lens combinations. Lens system shown viewed from side of signal; beam coverages shown looking down on track.

Replacing a Broken Lens or Roundel

1. Make sure that the replacement lens or roundel is of the same design as the original. This is particularly important as concerns the lens. The Type SA signal stepped lens has a 5-inch focal length, the designation for which is molded in the rim of the lens, for example: 8-3/8D x 5F etc. Make certain that the term "5F" appears in the designation.
2. Before installing the new lens or roundel, apply a sealing compound (such as Vulcatex) on the surface of the bezel ring to prevent water from entering.
3. Tighten screws evenly around the bezel ring to avoid the possibility of cracking the glass.

The Optical System

Two basic lens systems are available:

1. The compound-lens system, consisting of two plano-convex lenses, having smooth surfaces on both sides, Figure 14.
2. The stepped-lens system, consisting of a single lens, which has a smooth, convex outer surface and concentric circular steps on the concave inner surface, Figure 15.

The optical system of the compound-lens signal, Figure 14, consists of:

1. The lamp.
2. The reflector unit.
3. Color discs: red, yellow, green, or any other standard signal color.
4. The inner lens.
5. The outer lens.

Spreader and deflector roundels are added as required.

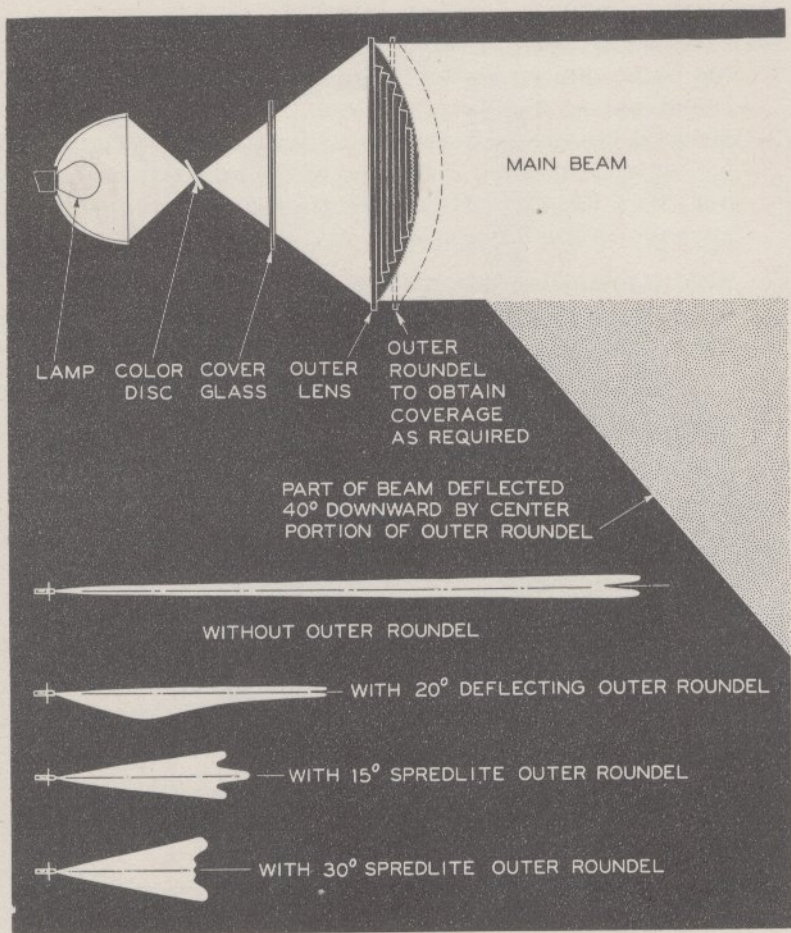

Figure 15. Stepped-lens system showing beam coverages with different lens combinations. Lens system shown viewed from side of signal; beam coverages shown looking down on track.

The stepped-lens signal, Figure 15, has the same units in the optical system, except that the inner lens is replaced by a plain cover glass, and the plano-convex outer lens is replaced by a stepped lens. Outer lenses 8-3/8 inches in diameter are standard equipment. Where close clearances require it, a 6-3/8-inch stepped lens can be furnished.

With the same wattage lamp the compound-lens system gives a beam of longer range. It is particularly effective, for primary-battery operation, for which 8- or 10-volt, 5-watt lamps are available. This lens system is also frequently used with higher wattage lamps on storage-battery supply.

Outer roundels are added as required to spread the beam to suit the curvature of the tracks.

Why the Red Color Disc is Slanted

It has been found that under certain conditions the red signal light has been diluted by the light from the approaching engine's headlight. To create this condition it was necessary to have the headlight, signal, and the engine-man's eyes on the same level.

This dilution created a weaker, paler aspect. Laboratory experiments proved that the direct white light from the headlight of a locomotive was concentrated on the mirror-like surface of the vertical color disc and was reflected to the engineman, mixed in with the signal beam, thus diluting the color.

In the SA signal the red color disc is slanted away from the vertical so that extraneous light is now reflected upwards and into the serrated cone where it is absorbed. Thus the undiluted color beam is transmitted.

Changing Signal from Straight Track to Curved Track Application, Figures 14 and 15

As shown in Figures 14 and 15, various outer roundels are available to adapt Type SA signals to the many topographical conditions encountered in railroad practice. When changing a Type SA signal from a straight to a curved track application, the proper deflecting or spreadlite roundel should be selected in accordance with directions given in Pamphlet 530, "How to Select the Proper Optical Combination for Any Given Condition." In addition to the proper roundel with its gasket, the following will be required:

Quantity	Description	Drawing Reference
1	Adapter Ring	43983-46
4	Screws (for compound lens)	33287-8
4	Screws (for stepped lens)	33287-13

When these materials have been secured proceed as follows:

1. Remove outer ring on which sheet-metal hood is mounted. Be careful that lens does not fall out of its bezel ring.
2. Assemble adapter ring 43983-46 after first applying sealing compound to machined surfaces.
3. Assemble roundel in position to direct the deflecting or spread beam in the required direction. A single arrow molded in the glass of the deflecting roundel indicates the direction in which it deflects the beam. A double arrow molded in the glass of the spreadlite roundel indicates the two directions in which it spreads the beam.

4. Place outer ring over roundel and fasten with the four longer screws, tightening the screws evenly around the ring.

Check These Before Placing Signal in Service:

1. Be sure that the operating current is correct if it is a d-c. mechanism or that the operating voltage is correct if it is an a-c. mechanism.
2. Be sure that the reflector and lenses are clean.
3. Be sure that the lamp is clean and properly seated in its socket.
4. Be sure that the signal is properly aligned. Check both horizontal and vertical adjustments.
5. Be sure that all adjustments are properly tightened to avoid subsequent movement of the signal.
6. Be sure that the proper lens combination is used for the particular track conditions at the location.
7. Be sure that the mechanism is properly locked in the housing and that the reflector unit is in place and locked.

Don'ts

1. Don't change the reflector or socket adjustment. This has been factory adjusted and should never be touched. If the aspect is not satisfactory, the trouble may be caused by:
 - (a) Low voltage at lamp terminals.
 - (b) Signal improperly aligned with respect to the track.

- (c) Wrong lens and/or roundel combination for the location.
 - (d) Wrong reflector unit - each reflector holder is marked "For Compound Lens" or "For Stepped Lens".
2. Don't open the signal mechanism on the right-of-way. Seals on the mechanism should not be broken, nor the mechanism opened, except where adequate facilities are available for repairs.
 3. Don't oil the signal mechanism at any time. It is equipped with bearings which require no lubrication whatever.
 4. Don't check voltage at the source of supply - there is always a line drop in potential which makes such a check useless. Measure voltage at the lamp terminals and measure operating currents through the relay coils.
 5. Don't burn the lamp at a lower voltage than that recommended.
 6. Don't burn the lamp at excessive voltage; as a general rule never exceed rated voltage.
 7. Don't force excessive current through the operating coil.
 8. Don't expect a lens projecting a concentrated beam to cover a curved track.
 9. Don't expect a beam with wide spread to have the same range as a concentrated beam.
 10. Don't remove or readjust the sighting device. This has been factory adjusted and should not be changed.

Ordering References

Ordering information for Type SA signals is in the following catalog sections:

Mechanisms and housings - Section H, Part 26.

Lamps - Section H, Part 39.

Lenses and roundels - Section H, Part 40.

If you do not have a G-R-S Catalog available and if the part you want is not in the following list, describe the part as accurately as possible in your order and give us the drawing number stamped on the name plate attached to the signal operating mechanism.

1. Adjustable Lamp Resistance - Order by giving the drawing number stamped on the mechanism name plate.
2. Reflector Unit - If the reflector is broken, it may be replaced without disturbing the lamp-socket adjustment. However, better results will be obtained by returning the reflector holder to us. Give us the drawing number stamped on the mechanism name plate and also the drawing number of the lamp. We will replace the reflector and refocus the unit.
3. Coils - Give us the drawing number stamped on the mechanism name plate.
4. Glass Case - Should glass case protecting the working parts of the signal operating mechanism be broken, order a new one as follows: "one glass case for Type SA signal - drawing number 37380-8."

DISTRICT OFFICES

NEW YORK OFFICE

230 Park Avenue, New York 17, New York
Telephone: MURray Hill 9-7533

CHICAGO OFFICE

122 South Michigan Avenue, Chicago 3, Illinois
Telephone: HARRison 2361 and 2362

ST. LOUIS OFFICE

611 Olive Street, St. Louis 1, Missouri
Telephone: Main 4696

EASTERN CANADIAN OFFICE

William S. Henry, P. O. Box 600, Rochester 2, New York
Telephone: Genesee 1483

WASHINGTON OFFICE

508 Metropolitan Bank Bldg.
613 15th St., N.W., Washington 5, D.C.
Telephone: EXECutive 4757

REPRESENTED IN

Argentina, Australia, Brazil, Chile, China, England,
Principal European Countries, Federated Malay States,
India, South Africa and New Zealand

